

# SPECIFICATION FOR APPROVAL

## 承 认 书

Description : Magnetic Buzzer

Vender's Part No. : SMD-080025H-03627JN

Customer's. Part No. : \_\_\_\_\_

Serial No. : FDM-2986

Version No. : 1.1

CUSTOMER'S APPROVED SIGNATURE		



**JIANGYIN FUDING ELECTRONIC CO.,LTD**

**江 阴 福 鼎 电 子 有 限 公 司**

YueFeng Road, Yue Cheng Town, Jiang Yin City.

TEL: +86-0510-86582084

FAX: +86-0510-86586736

E-Mail: [tj@jy-fuding.com](mailto:tj@jy-fuding.com)/[fudingdz@126.com](mailto:fudingdz@126.com)

Http: [//www.jy-fuding.com](http://www.jy-fuding.com)

Approved By	Checked By	Made By

## A. SCOPE

This specification applies magnetic buzzer, **SMD-080025H-03627JN**

## B. SPECIFICATION

No.	Item	Unit	Specification	Condition
1	Oscillation Frequency	Hz	2730	Vo-p=1/2duty , square wave
2	Operating Voltage	Vo-p	2.5~4.5	
3	Rated Voltage	Vo-p	3.6	
4	Current Consumption	mA	MAX. 100	at Rated Voltage
5	Sound Pressure Level	dB	MIN. 85	at 10cm at Rated Voltage
6	Coil Resistance	$\Omega$	16 $\pm$ 3	
7	Operating Temperature	$^{\circ}$ C	-40 ~ +85	
8	Storage Temperature	$^{\circ}$ C	-40 ~ +85	
9	Dimension	mm	8.0 x 8.0 x H2.5	See appearance drawing
10	Weight (MAX)	gram	0.5	
11	Housing Material		LCP( Black )	
12	Leading Pin		Tin Plated Brass(Au)	See appearance drawing
13	Environmental Protection Regulation		RoHS	

## C. APPEARANCE DRAWING

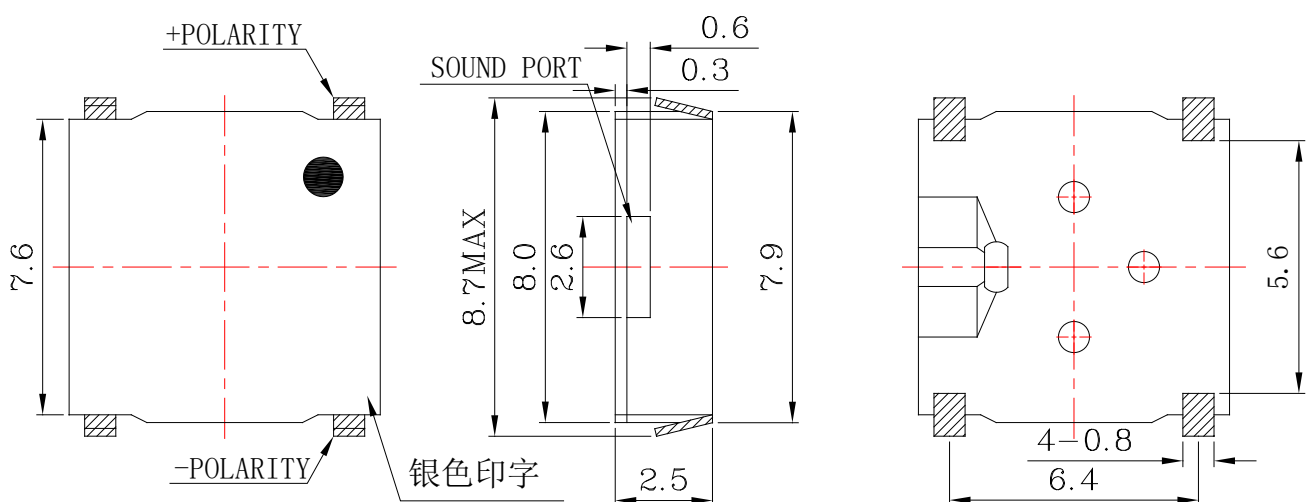

Tol : ± 0.2

Unit: mm



## D. TESTING METHOD

### Standard Measurement conditions

Temperature:  $25 \pm 2^\circ\text{C}$  Humidity: 45-65%

### Acoustic Characteristics:

The oscillation frequency, current consumption and sound pressure are measured by the measuring instruments shown below

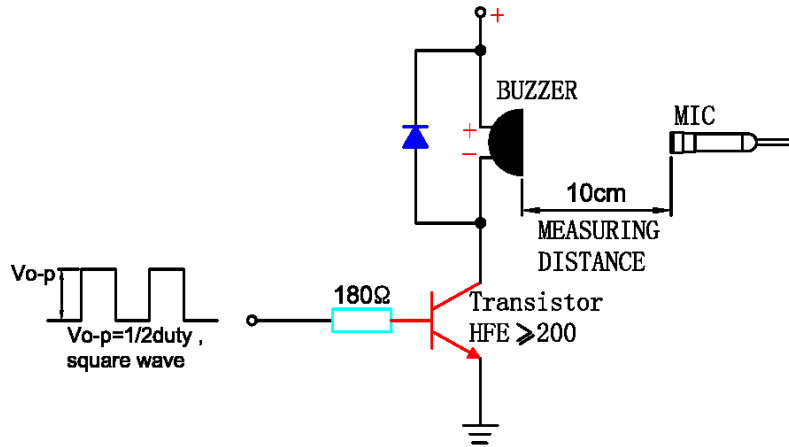

In the measuring test, buzzer is placed as follows:

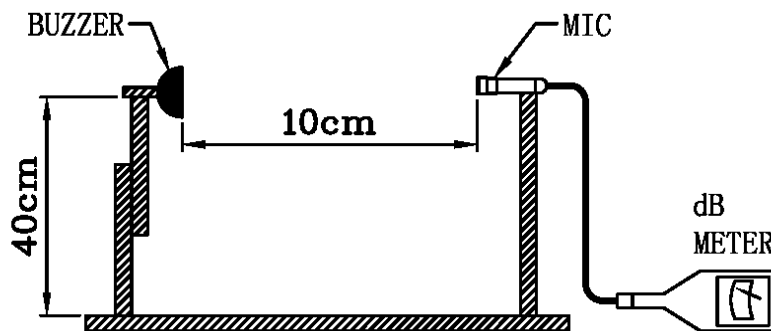

## E. Typical Frequency Response Curve

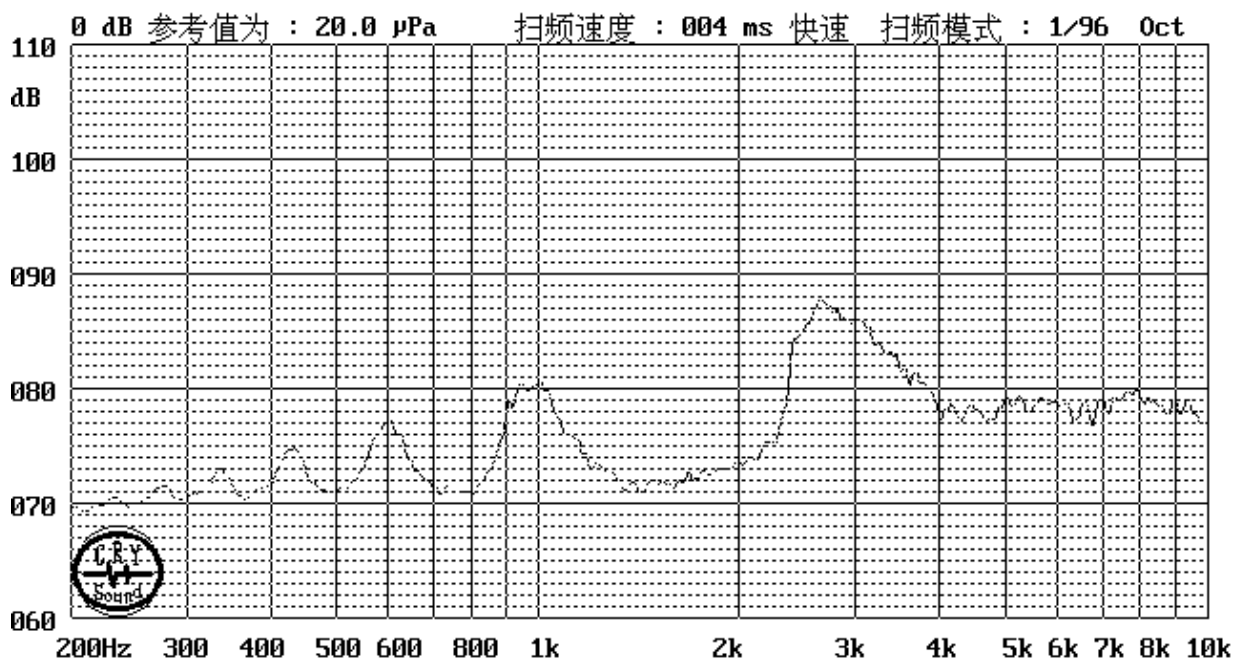

## F. Recommend Driving Circuit

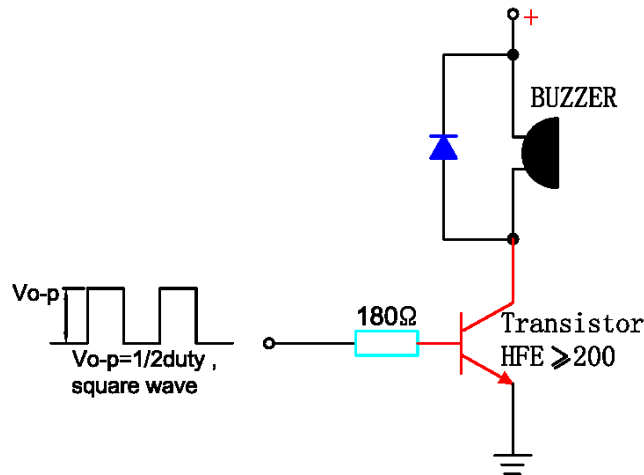

The base current  $I_b$  should be high enough so that it saturates the collector current of the transistor with the CB load.

## G. Soldering Condition

- (1) Recommendable reflow soldering condition is as follows  
(Reflow soldering is twice)

Note: It is requested that reflow soldering should be executed after heat of product goes down to normal.

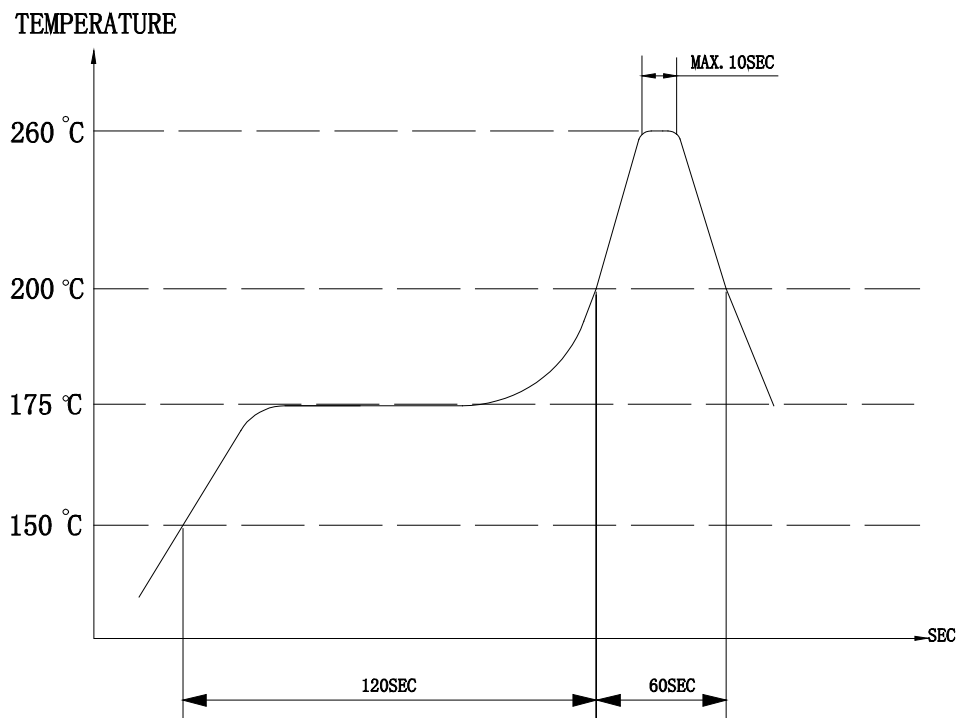

Heat resistant line

(Used when heat resistant reliability test is performed)

- (2) Manual soldering

Manual soldering temperature 350° C within 5 sec.

## H. RELIABILITY TEST

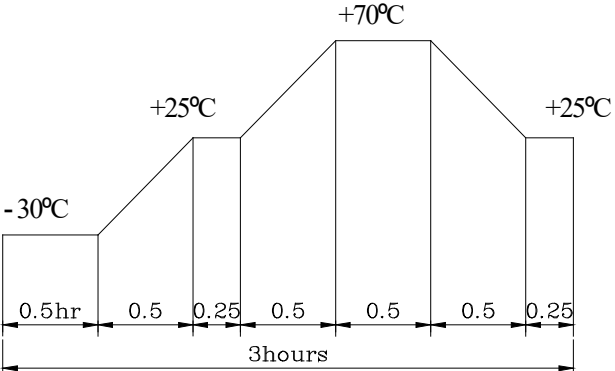
NO.	ITEM	TEST CONDITION AND REQUIREMENT
1	High Temperature Test (Storage)	After being placed in a chamber with 80 2°C for 96 hours and then being placed in normal condition for 2 hours. Allowable variation of SPL after test:   10dB.
2	Low Temperature Test (Storage)	After being Placed in a chamber with -50 2°C for 96 hours and then being placed in normal condition for 2 hours. Allowable variation of SPL after test:   10dB.
3	Humidity Test	After being Placed in a chamber with 90-95% R.H. at 40 2°C for 96 hours and then being placed in normal condition for 2 hours. Allowable variation of SPL after test:   10dB.
4	Temperature Cycle Test	<p>The part shall be subjected to 5 cycles. One cycle shall be consist of :</p>  <p>The diagram shows a temperature cycle profile over a total duration of 3 hours. The cycle starts at -30°C for 0.5 hours, then ramps up to +25°C in 0.5 hours, holds at +25°C for 0.25 hours, ramps up to +70°C in 0.5 hours, holds at +70°C for 0.5 hours, ramps down to +25°C in 0.5 hours, holds at +25°C for 0.25 hours, and finally ramps down to -30°C in 0.5 hours. The total duration is 3 hours.</p> <p>Allowable variation of SPL after test:   10dB.</p>
5	Drop Test	Drop on a hard wood board of 4cm thick, any directions ,6 times, at the height of 75cm . Allowable variation of SPL after test:   10dB.
6	Vibration Test	After being applied vibration of amplitude of 1.5mm with 10 to 55 Hz band of vibration frequency to each of 3 perpendicular directions for 2 hours . Allowable variation of SPL after test:   10dB.
7	Solderability Test	Lead terminals are immersed in rosin for 5 seconds and then immersed in solder bath of +300 5°C for 3 1 seconds . 90% min. lead terminals shall be wet with solder (Except the edge of terminals).
8	Terminal Strength Pulling Test	The force of 9.8N(1.0kg) is applied to each terminal in axial direction for 10 seconds. No visible damage and cutting off.

### TEST CONDITION.

Standard Test Condition	:	a) Temperature : +5 ~ +35°C	b) Humidity : 45-85%	c) Pressure : 860-1060mbar
一般测试条件	:	a) 温度 : +5 ~ +35°C	b) 湿度 : 45-85%	c) 气压 : 860-1060mbar
Judgment Test Condition	:	a) Temperature : +25 ± 2°C	b) Humidity : 60-70%	c) Pressure : 860-1060mbar
争议时测试条件	:	a) 温度 : +25 ± 2°C	b) 湿度 : 60-70%	c) 气压 : 860-1060mbar

# I. PACKING STANDARD

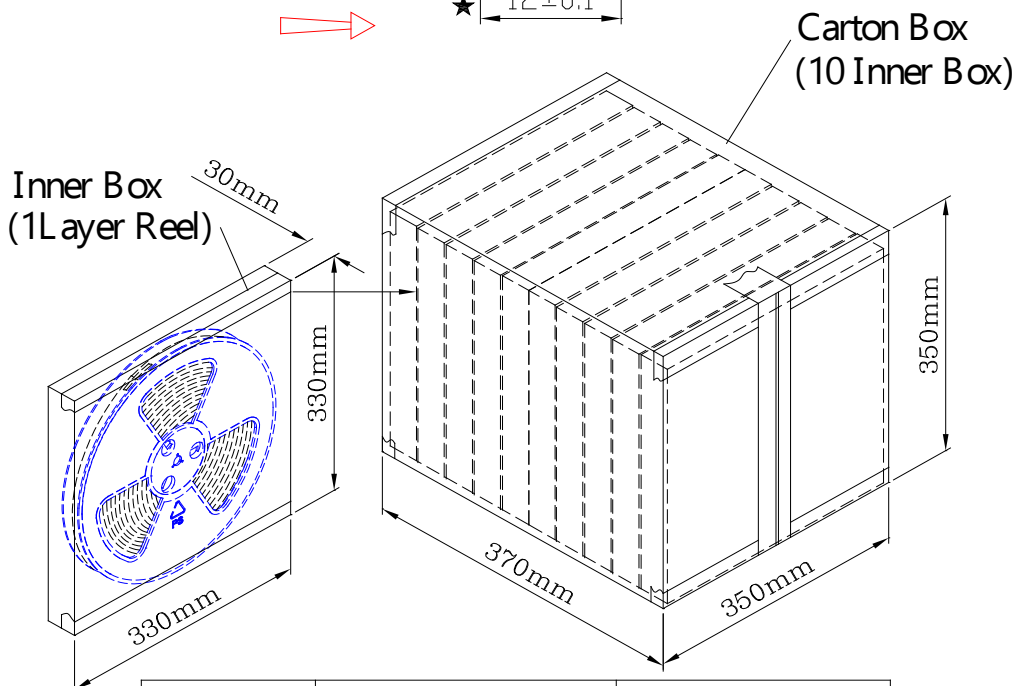
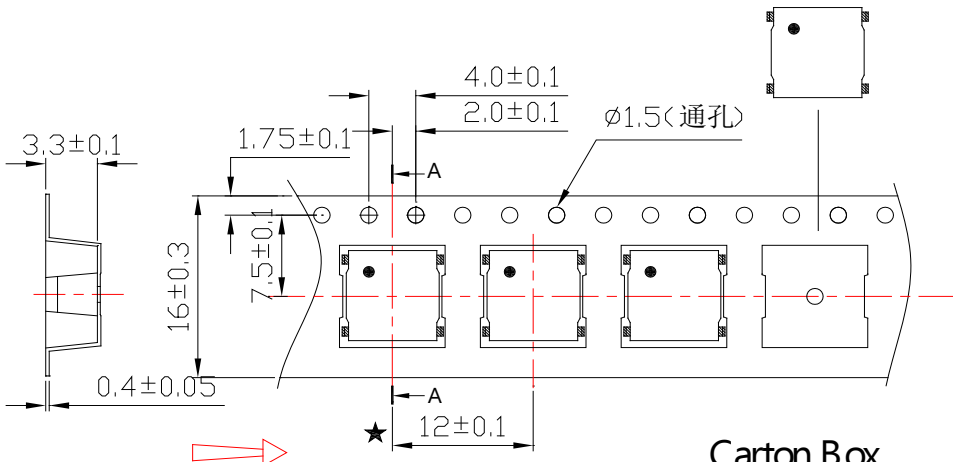
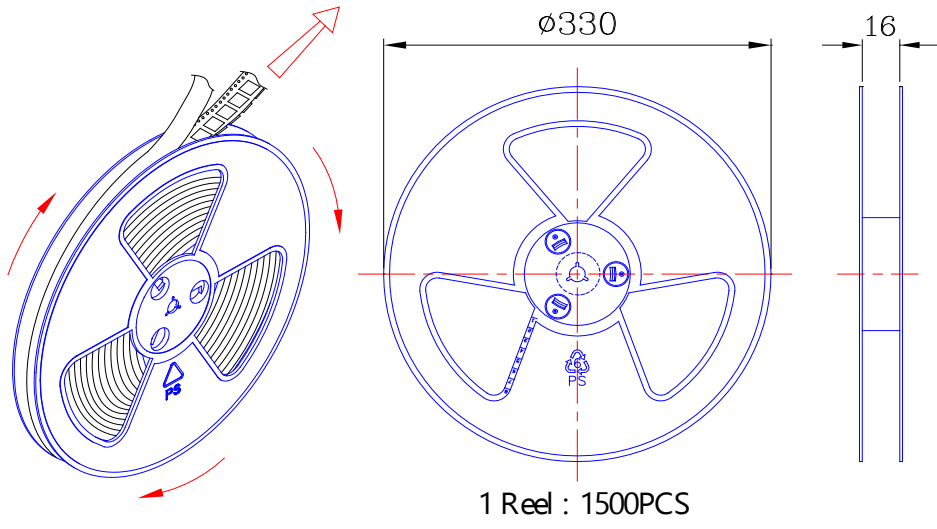

Inner Box	330mmx330mmx30mm	1x1500PCS=1500PCS
Carton Box	350mmx350mmx370mm	10x1500PCS=15,000PCS

